

# Hand pallet truck 2.3 ton

## BT lifter with Weight indicator



# Hand pallet truck

Truck specifications					LHM230WI
Identification	1.1	Manufacturer			BT
	1.2	Manufacturer's type designation			LHM230WI
	1.4	Operator type			Hand
	1.5	Load capacity/rated load	Q(t)	kg	2300
	1.6	Load centre distance	c	mm	600
	1.8	Load distance, front axle to fork face	x	mm	945 <sup>1)</sup>
	1.9	Wheelbase	y	mm	1170 <sup>1)</sup>
Weight	2.1	Service weight		kg	65
	2.2	Axle load, with load, drive/castor/fork wheel		kg	375/805
	2.3	Axle load, without load, drive/castor/fork wheel		kg	20/10
Wheels	3.1	Steer/fork wheels: Powerthane (Po), Steel (S) Nylon (N), Polyurethane (P), Rubber (R), Rubber antistatic (Ra)			Po, S, N, P, R, Ra/ Po, S, N, P
	3.2	Wheel size, front			175x60
	3.3	Wheel size, rear, single/bogie			85x100 / 85x75
	3.5	Steer wheels, number front/rear			2/2 or 2/4
	3.6	Track width, front	b <sub>10</sub>	mm	132
	3.7	Track width, rear	b <sub>11</sub>	mm	364
	Dimensions	4.4	Lift movement	h <sub>3</sub>	mm
		Lift height	h <sub>23</sub>	mm	200
4.9		Height of tiller in drive position, min./max.	h <sub>14</sub>	mm	1220
4.15		Height, lowered	h <sub>13</sub>	mm	85
4.19		Overall length	l <sub>1</sub>	mm	1510
4.20		Length to face of forks	l <sub>2</sub>	mm	365
4.21		Overall width	b <sub>1</sub>	mm	520/685
4.22		Fork dimensions	s/e/l	mm	45/156/1150 <sup>2)</sup>
4.25		Width over forks	b <sub>5</sub>	mm	520/685
4.32		Ground clearance, centre of wheelbase	m <sub>2</sub>	mm	40
4.33		Aisle width for pallets 1000 x 1200 crossways	A <sub>st</sub>	mm	1556
4.34		Aisle width for pallets 800 x 1200 lengthways	A <sub>st</sub>	mm	1725
4.35		Turning radius	W <sub>a</sub>	mm	1370

1) Distance with forks raised

2) Other fork length available: 800/910/1000/1070/1220

All data are based on table configuration. Other configurations may give other values.

Truck performance and dimensions are nominal and subject to tolerances.

Specifications are subject to change without notice.

Scale data		LHM230WI	
Scale data	Maximum inaccuracy, applied weight	kg	0-200 = ± 10 kg
		kg	201-1000 = ± 20 kg
		kg	> 1000 = ± 50 kg
	Battery	V	4 x 1.5 AA size
	Battery length of life		3000 weighings

# Dimensional drawings

# BT lifter with Weight indicator

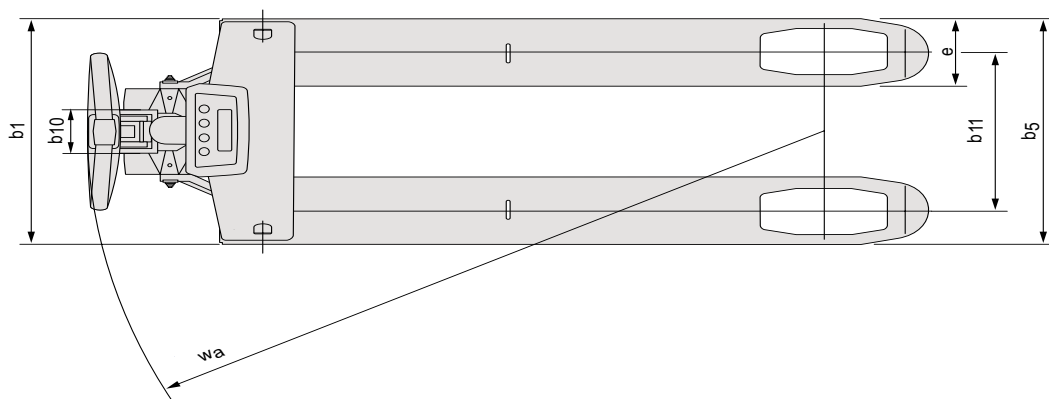
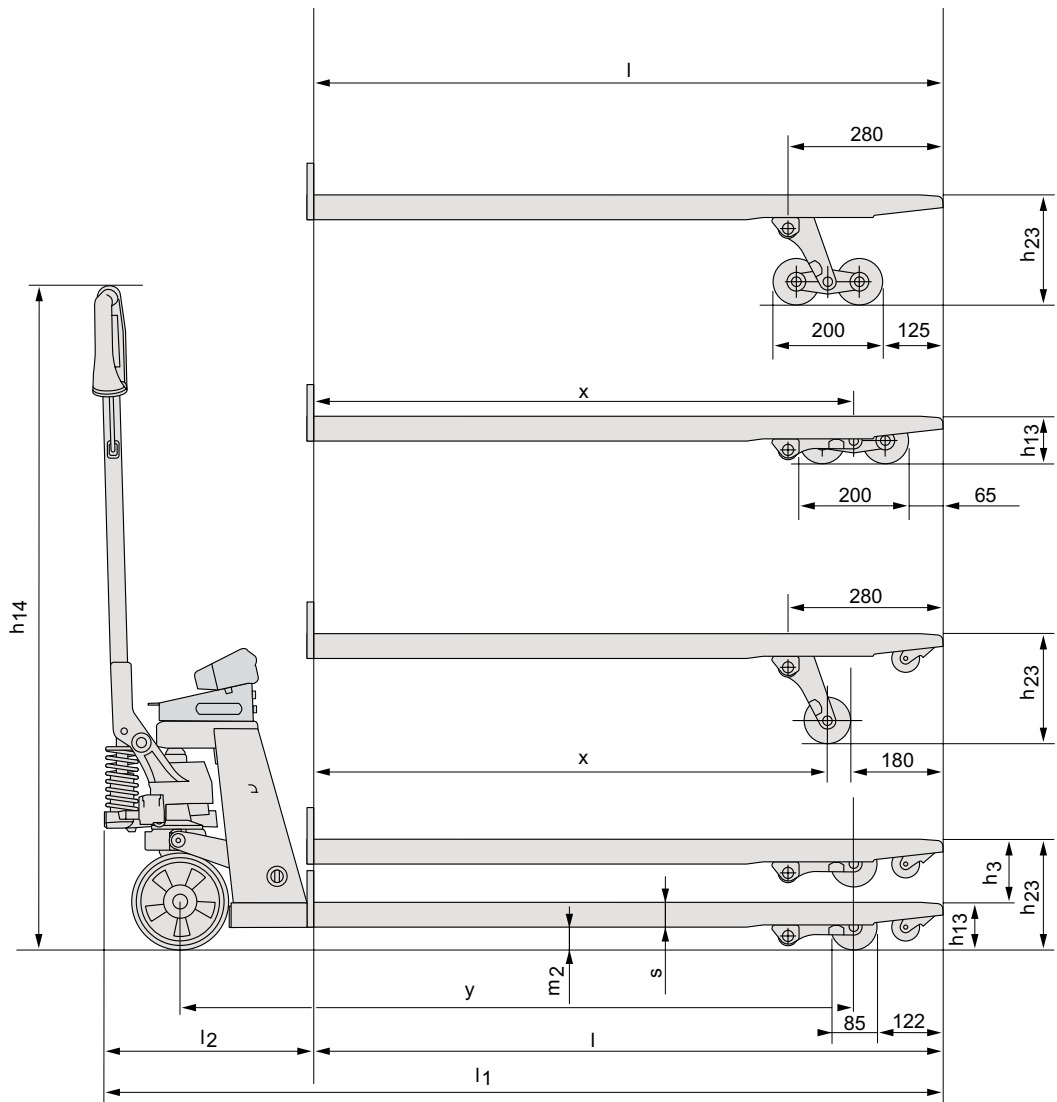

---

## Truck features:

- For simple mobile weight indication: on board lorries, at goods receptions, determining shipping weights, avoiding overload, approximate pallet weights.
- Equipped with Quick Lift function as standard.
- A perfect combination of quality and reliability, easy to serve and very user friendly.
- Greasable bushings ensure a long service life.
- Many wheel options to optimize the wheel resistance for different flooring material.
- The robust forks are made in one piece, and the rounded fork tips makes it easy to move in and out of pallets.
- This product has been environmentally declared.

