

Engine Powered Forklift 1.5 - 2.0 ton

BT cargo

C4D/G150D

C4D/G180D

C4D/G200D



Engine Powered Forklift 1.5-2.0 ton

Truck specifications					C4D150D/C4G150D	C4D180D/C4G180D	C4D200D/C4G200D
Identification	1.1	Manufacturer			BT	BT	BT
	1.2	Model			C4D150D/C4G150D	C4D180D/C4G180D	C4D200D/C4G200D
	1.3	Drive			Diesel/GPL	Diesel/GPL	Diesel/GPL
	1.4	Operator type			Rider seated	Rider seated	Rider seated
	1.5	Load capacity/rated load	Q	kg	1500	1800	2000
	1.6	Load centre	c	mm	500	500	500
	1.8	Load distance, centre of drive axle to fork	x	mm	390 ¹⁾	390 ¹⁾	390 ¹⁾
	1.9	Wheelbase	y	mm	1490	1490	1490
	Weight	2.1	Service weight		kg	2870	2970
2.2		Axle load, with load, front/rear		kg	3700/670	4210/560	4570/500
2.3		Axle load, without load, front/rear		kg	1300/1570	1330/1640	1360/1710
Tyres	3.1	Tyres: Cushion (C), Pneumatic (PN), Superelastic (SE), Twin (TW)			SE/PN/SE.TW ²⁾	SE/PN/SE.TW ²⁾	SE/PN/SE.TW ²⁾
	3.2	Tyre size, front			23x9-10/23x9-10/ 6,50-10 ³⁾⁴⁾⁵⁾	23x9-10/23x9-10/ 6,50-10 ³⁾⁴⁾⁵⁾	23x9-10/23x9-10/ 6,50-10 ³⁾⁴⁾⁵⁾
	3.3	Tyre size, rear			18x7-8/18x7-8	18x7-8/18x7-8	18x7-8/18x7-8
	3.5	Wheels, number front/rear (x=driven wheels)			2x-4x/2	2x-4x/2	2x-4x/2
	3.6	Track width, front	b ₁₀	mm	892/922/1061	892/922/1061	892/922/1061
	3.7	Track width, rear	b ₁₁	mm	863	863	863
	Dimensions	4.1	Tilt of mast/fork carriage forward/backward		α/β	deg	5°/10°
4.2		Height, mast lowered		h ₁	mm	2160	2160
4.3		Free lift		h ₂	mm	80	80
4.4		Lift		h ₃	mm	3170	3170
		Lift height		h ₂₃	mm	3205	3205
4.5		Height, mast extended		h ₄	mm	3720	3720
4.7		Height of overhead guard (cab)		h ₆	mm	2120	2120
4.8		Seat height/stand height		h ₇	mm	1040	1040
4.12		Coupling height		h ₁₀	mm	330	330
4.19		Overall length		l ₁	mm	3275 ¹⁾	3275 ¹⁾
4.20		Length to face of forks		l ₂	mm	2275 ¹⁾	2275 ¹⁾
4.21		Overall width		b ₁	mm	1098/1162 ³⁾⁴⁾⁵⁾	1098/1162 ³⁾⁴⁾⁵⁾
4.22		Fork dimensions		s/e/l	mm	35/100/1000	35/120/1000
4.23		Fork carriage DIN 15 173, class/type A, B				IIA	IIA
4.24		Fork-carriage width		b ₃	mm	900	900
4.31		Ground clearance, with load, below mast		m ₁	mm	89	89
4.32		Ground clearance, centre of wheelbase		m ₂	mm	125	125
4.33	Aisle width for pallets 1000 x 1200 crossways		A _{st}	mm	3659 ¹⁾	3659 ¹⁾	
4.34	Aisle width for pallets 800 x 1200 lengthways		A _{st}	mm	3859 ¹⁾	3859 ¹⁾	
4.35	Turning radius		W _a	mm	2069	2069	
4.36	Internal turning radius		b ₁₃	mm	583	583	
Performance data	5.1	Travel speed, with/without load			km/h	17,0/18,0	17,0/18,0
	5.2	Lift speed, with/without load			m/s	0,50/0,55	0,50/0,55
	5.3	Lowering speed, with/without load			m/s	<0,55	<0,55
	5.5	Drawbar pull, with/without load			N	9500/9500	9500/9500
	5.7	Gradeability, with/without load			%	19/27	17/27
	5.10	Service brake				Hydraulic	Hydraulic
Combustion engine	7.1	Engine manufacturer/type				Toyota 1DZ-III/Toyota 4Y	
	7.2	Engine power acc. to ISO 1585			kW	38/37	38/37
	7.3	Rated speed			1/min	2400/2400	2400/2400
	7.4	No. of cylinders/displacement			cm ³	4-2486/4-2237	4-2486/4-2237
Others	8.1	Type of drive control				Stepless hydrostatic	Stepless hydrostatic
	8.2	Operating pressure for attachments			bar	180	180

1) With sideshift = +34 mm

2) TW not available with triplex mast

3) On request SE 6.50-10. b₁=1043mm. Track width 872mm

4) Chassis width with triplex mast and SE (6.50-10)
= 1105mm. Track width 934mm

5) Chassis width with triplex mast and PN (6.50-10)
= 1155mm. Track width 964mm

Performance data and dimensions are nominal and subject to tolerances.
Specifications are subject to change without notice.
Please obtain the latest specifications before contracting products.

Mast dimensions and rated capacities

BT cargo

Mast		Duplex					Duplex FFL				Triplex				Triplex FFL								
C4D/G150D-200D	Lift height	h_{23}	3005	3205	3705	4205	4705	2875	3205	3705	4205	4355	5000	5600	6200	6605	4355	4505	5005	5605	6205	6605	7005
	Lift	h_3	2970	3170	3670	4170	4670	2840	3170	3670	4170	4320	4965	5565	6165	6570	4320	4470	4970	5570	6170	6570	6970
	Height, mast lowered	h_1	2060	2160	2410	2660	2910	1990	2160	2410	2660	2010	2260	2460	2710	2860	2010	2060	2260	2460	2710	2860	3010
	Height, mast extended	h_4	3520	3720	4220	4720	5220	3420	3750	4250	4750	4900	5570	6170	6820	7240	4900	5050	5550	6150	6750	7150	7550
	Free lift	h_2	80	80	80	80	80	1410	1580	1830	2080	0	0	0	0	0	1430	1480	1680	1880	2130	2280	2430

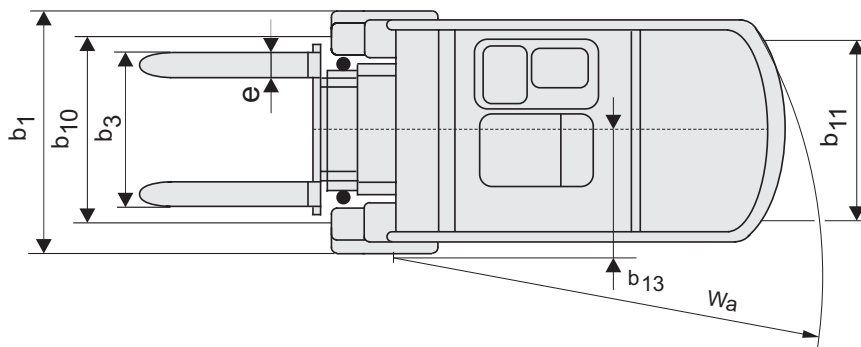
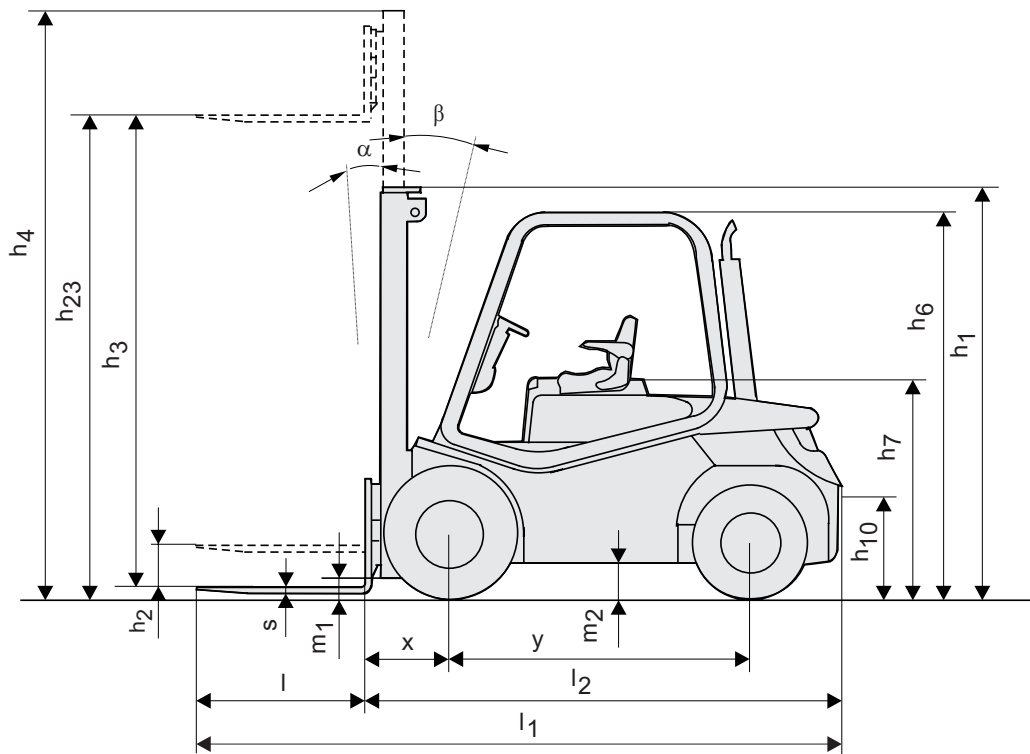

Standard equipment:

- Hydrostatic transmission
- Long forks (1000 mm)
- Tilting mast
- Side-shift
- Balanced pedals control
- Clear-view mast
- Driver detection system
- Adjustable steering wheel



TP-Technical Publications, Sweden — 745580-040, version 1, 1203

