

Very narrow aisle truck 1.0 - 1.2 ton

BT vector

C-series

VCE100

VCE120



Very Narrow Aisle truck

Truck specifications					VCE100	VCE120
Identification	1.1	Manufacturer			BT	BT
	1.2	Model			VCE100	VCE120
	1.3	Drive			Electric	Electric
	1.4	Operator type			Stand-on/Seated	Stand-on/Seated
	1.5	Load capacity/rated load	Q	kg	1000	1200
	1.6	Load centre	c	mm	600	600
	1.9	Wheelbase	y	mm	1765	1765
Weight	2.1	Service weight with battery		kg	6100	6200
	2.2	Axle load, with load, drive/support arm wheel		kg	5390/1770	5550/1850
	2.3	Axle load, without load, drive/support arm wheel		kg	3640/2460	3740/2460
Wheels	3.1	Drive/support arm wheel			Vulkollan	Vulkollan
	3.2	Wheel size, front		mm	Ø 240x140	Ø 240x140
	3.3	Wheel size, rear		mm	Ø 406x178	Ø 406x178
	3.5	Wheels, number front/rear (x=driven wheels)			2/1x	2/1x
	3.6	Track width, front	b ₁₀	mm	1293	1293
	3.7	Track width, rear	b ₁₁	mm	0	0
	Dimensions	4.2	Height, mast lowered	h ₁	mm	3120
4.4		Lift movement	h ₃	mm	3900	3900
		Total lift height	h ₂₃	mm	5540	5540
4.5		Height, mast extended	h ₄	mm	6375	6375
4.7		Height of overhead guard	h ₆	mm	2470	2470
4.8		Step-in height	h ₇	mm	450	450
4.11		Additional lift	h ₉	mm	1600, 1800	1600, 1800
4.14		Platform, elevated	h ₁₂	mm	4350	4350
4.15		Height of lowered forks	h ₁₃	mm	60	60
		Height of auxiliary lift mast	h ₁₅	mm	2475, 2675	2475, 2675
4.19		Overall length, without load	l ₁	mm	3750	3750
4.20		Length to face of forks	l ₂	mm	3550	3550
4.21		Overall width	b ₁ /b ₂	mm	1070/1450	1070/1450
4.22		Fork dimensions	s/e/l	mm	100/40/1200	100/40/1200
4.23		Fork carriage DIN 15 173, class/type A, B			IIB	IIB
4.24		Fork-carriage width	b ₃	mm	832	832
4.25		Width over forks	b ₅	mm	772	772
4.29		Lateral reach	b ₇	mm	1340	1340
4.31	Ground clearance, with load, below mast	m ₁	mm	75	75	
4.33	Aisle width for pallets 1200 x 1200 crossways (rail)	A _{st}	mm	1660	1660	
4.35	Turning radius	W _a	mm	2080	2080	
4.38	Distance front axle to boom pivot	l ₈	mm	1246	1246	
Performance data	5.1	Travel speed, with/without load		km/h	10,5/10,5	10,5/10,5
	5.2	Lift speed, with/without load		m/s	0,40/0,40	0,40/0,40
	5.3	Lowering speed, with/without load		m/s	0,43/0,43	0,43/0,43
	5.4	Lateral reach, with/without load		m/s	0,40/0,40	0,40/0,40
	5.9	Acceleration time, with/without load (0-10m)		s	8,0/8,0	8,0/8,0
	5.10	Service brake			Electric	Electric
	5.11	Parking brake			Electro-mechanical	Electro-mechanical
Electric motor	6.1	Drive motor rating S2 60 min		kW	7,5	7,5
	6.2	Lift motor rating S3 15%		kW	25+3,5	25+3,5
	6.4	Battery voltage, nominal capacity K ₅		V/Ah	80/465	80/465
	6.5	Battery weight		kg	1240	1240
	6.6	Energy consumption acc to VDI cycle ¹⁾		kWh/h		
	Other	8.1	Type of drive control			Variable AC
8.4		Sound level at the driver's ear according to EN 12 053		dB(A)	65	65

1) Contact your supplier for information

All data are based on table configuration. Other configurations may give other values.

Performance and dimensions are nominal and subject to tolerances.

BT products and specifications are subject to change without notice.

Mast dimensions

BT vector

Mast				Duplex Tele					
VCE100/VCE120	Platform height	h_{12}	mm	3350	4350	5350	6350	7350	8350
	Lift movement	h_3	mm	2900	3900	4900	5900	6900	7900
	Total lift height ¹⁾	h_{23}	mm	4540	5540	6540	7540	8540	9540
	Picking height	h_{28}	mm	4950	5950	6950	7950	8950	9950
	Height, mast lowered	h_1	mm	2620	3120	3620	4120	4620	5120
	Height, mast extended	h_4	mm	5375	6375	7375	8375	9375	10375

1) $h_{23} = h_3 + h_9 + s$ ($h_9 = 1600$ mm)

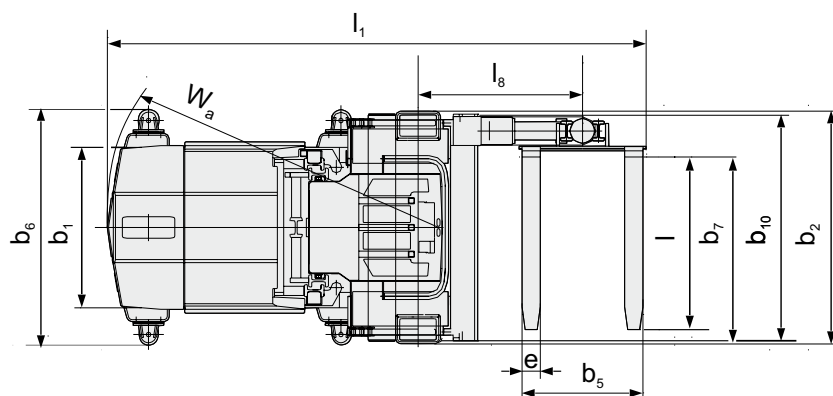
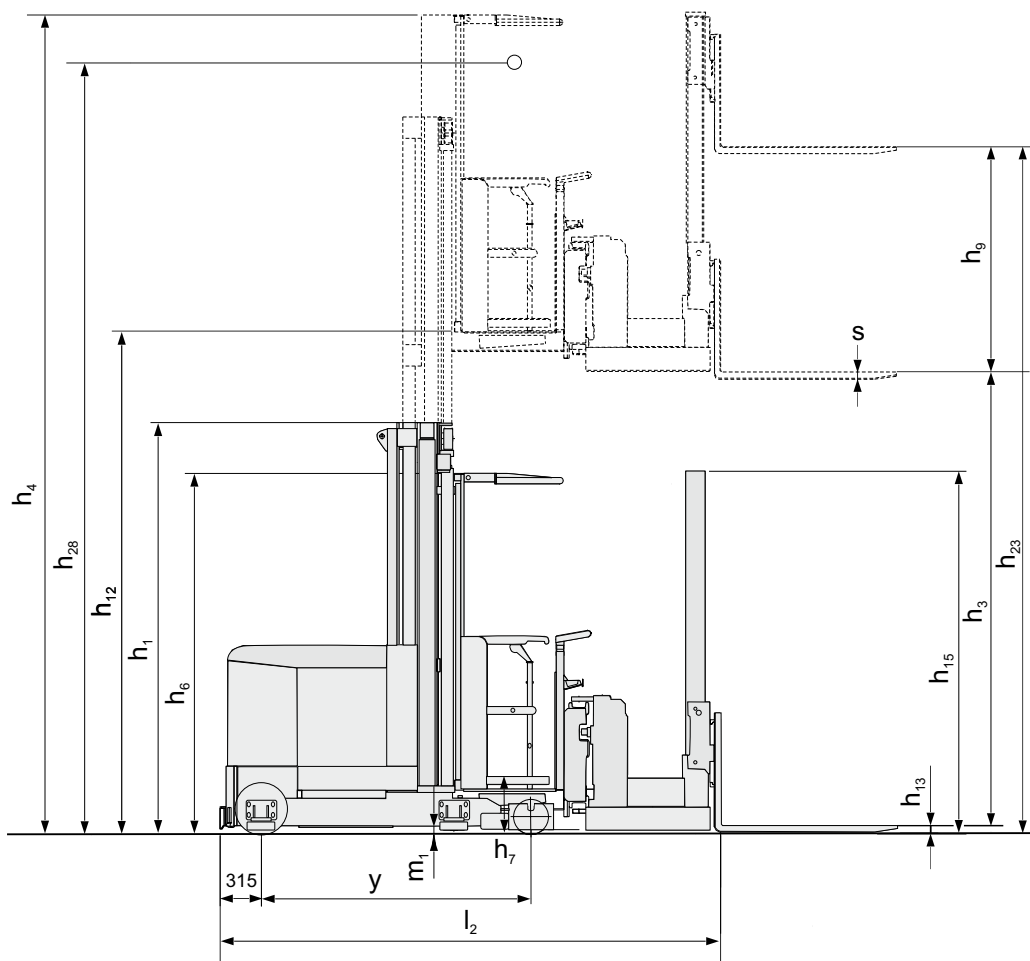

Truck features:

- BT Optipace system
- Wire/rail guidance
- Electronic steering
- Steering direction indicator
- Automatic deceleration
- Electronic braking system
- Adjustable seat
- Battery status indicator
- Battery discharge prevention system

